



GENERAL THERMOSTATIC INFORMATION

Please read the complete Thermostatic instructions and cautions contained in this booklet before attempting to install the Thermostatic Valve System. Please be sure the Homeowner is provided the booklet for future reference for regular maintenance.

STEP 1 - Read the entire booklet first.

STEP 2 - Connect the hot water to the side with red mark (+) and the cold water to the side with the blue mark (-). SEE CAUTIONS. Inlets are 3/4" NPT, Outlets are 1/2" NPT.

STEP 3 - The depth of the valve should be installed using print # 2. Valve is shipped with maximum extension.

STEP 4 - Connect the exit(s) required to 1/2" NPT copper pipe. Inlet shut-off valves are screwdriver spring check valves. The volume controls are 1/4 turn ceramic disk cartridges. Any debris in the cartridges may allow exits to drip. If you only need (1) exit, properly plug the 2nd exit. DO NOT USE HEAT OR TORCH.

STEP 5 - Open both screw driver spring check valve inlet ports and pressure test all connections with water. Check for flow and leaks before closing the walls.

STEP 6 - Be sure the hot water heater is connected, clean and operational. Before you calibrate the cartridge, set the hot water to approximately 130° - 140° Fahrenheit. If there is no hot water, you cannot test the system for proper performance.

STEP 7 - The center of the valve is where the thermostatic cartridge is located. The cartridge only controls the mixed water temperature and must be "calibrated " to protect the end user while bathing. Calibration is simple but will take 5 to 7 additional minutes to set the mixed water temperatures to hot and cold limits. You control the temperature range of mixed water through calibration.

Rotate the square (or spline adapter A) tube located on the thermo cartridge all the way to the right (clockwise) and you have the maximum cold water. Reverse (counter-clockwise) and you have the maximum incoming hot water. The set point is up to you. Feel the mixed water at the exit. Let water run for 2 or 3 minutes to confirm comfort level. Install the cover plate. Dial and pointer The dial represents a numerical location i.e. 80 where you will place the red pointer to remind you the bather of comfort temperature location.

STEP 8 - HIGH TEMP LIMIT SET POINT TRIM! The combined trim (The Dial Pointer Assembly) has a built-in stop and a manual override which limits the distance the handle will be allowed to turn in the hot direction. If you have calibrated the valve correctly, this CAN prevent children, elderly, and handicapped people from the danger of excessive hot water.

STEP 9 - You are now ready to enjoy your new Eurotherm system.



FEATURES:

- 1/2" systems come with 1/4 turn ceramic disc cartridges volume controls.
- Service shut-off valves are screwdriver spring check valves. Other sizes may have optional shut-offs, ask dealer for details.
- The 1/2" full-flow Thermostatic uses a parafin wax sensitivity cartridge.
- The 1/2" cartridge constantly monitors temperature and re-adjusts within 2°F of set temperature when supply pressure fluctuates, re-adjustment occurs in less than 2 seconds.
- The Eurotherm brand of Thermostatic valves have been in use worldwide for over fifty years.
- Complete serviceability from front of all units.
- Extension kits are available through your dealer at an extra charge.
- Keep in mind that the distance the shower head or other exit is from the valve determines how quickly temperature change is felt.
- 1/2" and 3/4" size valves come with dual exits as a standard feature. Plumber may plug one exit.

INSTALLATION CAUTIONS!

1. State of the art CNC Machining and 1/4 turn ceramic disc cartridges mean precision made product. NO HEAT, NO TORCH ... Shall be applied to the valve assembly.
2. Install adapters at each port, seal the joint, and then run the required copper lengths to the incoming water. Solder the copper connection a minimum of 8" away from valve body.
3. Use approved thread sealers at all joints. DO NOT USE PLUMBERS PUTTY, USE OF ANY CAUSTIC MATERIAL MAY HARM THE FINISH AND/OR INTERFERE WITH PROPER FUNCTION OF THE CARTRIDGE.
4. Prior to installing the thermostatic cartridge, flush all water lines to free up all
5. solder, sand, silt, and debris that have loosened up from the installation process. The lines should be flushed long enough to remove any sediment that may come from any new additional installation such as a water heater.
6. Failure to flush all water lines properly may damage internal parts. An In-Line water filter is recommended to remove harmful sediment.
7. Inlet screwdriver spring check valves are provided with the 1/2" full-flow system.
8. All valves that are not tooled with NPT connectors come with conversion adapters.
9. For proper flow rates and multiple exit installations check with your authorized dealer for installation assistance. When installing body sprays with 1/2" systems, no more than three sprays should be plumbed out of the top outlet for maximum flow in conjunction with a pressure balancing loop.
10. Remember water pressure comes from your local water supplier and can be measured at the source on the street.
11. Pressure or water velocity is not a function of the valve.
12. The water meter that is supplied for your home should be 25% larger than the water line supply on your recirculation loop for maximum flow rates from the valve.
13. Do not attempt installation of the product if you do not understand these instructions.
14. Qualified plumbers should be used for all installation procedures.



FAILURE TO FOLLOW INSTRUCTIONS MAY CAUSE DAMAGE OR IMPROPER OPERATION AND VOID THE WARRANTY.

Please read the complete Thermostatic instructions and cautions contained in this booklet before attempting to install the Thermostatic Valve System.

1. Flush all rough-in piping thoroughly to remove sediment, flux and other debris.
2. Hot and cold inlets are clearly marked. DO NOT REVERSE CONNECTIONS, THE UNIT WILL NOT WORK CORRECTLY.
3. DO NOT USE DIRECT HEAT, OR ANY TORCH ON 1/2" ROUGH VALVES.
4. Minimum and maximum finished wall tolerances are clearly marked.
5. It is extremely important that the rough mixing chamber be free of all debris before installation of the thermostatic cartridge. Read all instructions on boxes, valves and cartridges.
6. Under no circumstances should the thermostat cartridge be dismantled. Doing so will void any warranty and generally make the cartridge inoperable.

MAINTENANCE

Soaking the cartridge in a 50/50 solution of clear household vinegar and water will remove lime scale, and lime deposits caused from your water.

Regular cleaning each year will extend the life of the cartridge. Never use a screwdriver on any thermostatic cartridge. Never take a thermostatic cartridge apart as you will damage this precise instrument. Call your dealer or the factory for answers to your questions.

INSTALLATION AND PROPER ALIGNMENT OF CARTRIDGE FOR 2 EXIT BALANCED TEMPERATURE CONTROL

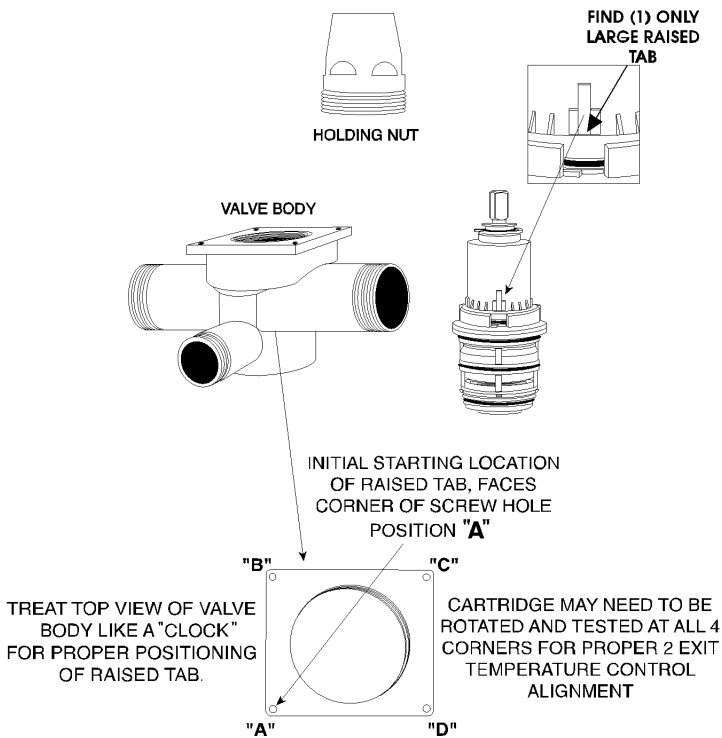

THERMOSTATIC 1/2" CARTRIDGE REMOVABLE FROM THE TOP

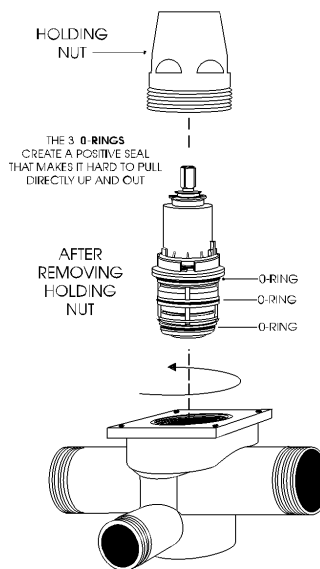

SPRING CHECK VALVE

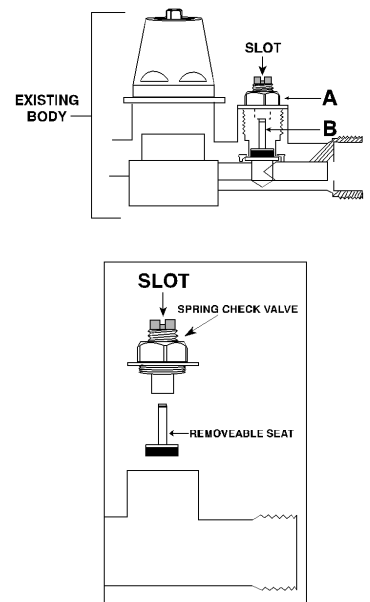

To remove cartridge from body: Rotate cartridge counter clockwise only.
To re-set: (Re-seal - Push straight into body and secure with holding nut)

PLEASE INSPECT PRODUCT PRIOR TO INSTALLING:

Carefully review all pre-assembled parts. It will be necessary for the various parts to be re-assembled correctly.

NOTICE:

These instructions do not represent step-by-step directions. They are a product supplement only to be used by a qualified/licensed plumber. We recommend all plumbing fixtures be installed by a professional.

- Check ports for markings.
- **NEVER** use an exit as an inlet; **NEVER** use an inlet as an exit.
- All connections are NPT.
- **NO HEAT - NO TORCH.**
- **FLUSH LINES OF DEBRIS.**
- **TEST UNIT BEFORE CLOSING WALL.**
- **UPC REQUIRES ACCESS TO MECHANICAL JOINTS.**

INSTRUCTIONS:

1. Mark threaded tube 1-7/8" from the wall.
2. Mark broach 2-1/2" from the wall.
3. Cut hardware to marked length.
4. Re-install hardware to valve.
5. Install trim plate and handles in the desired orientation.
6. Tighten temperature handle with set screws.

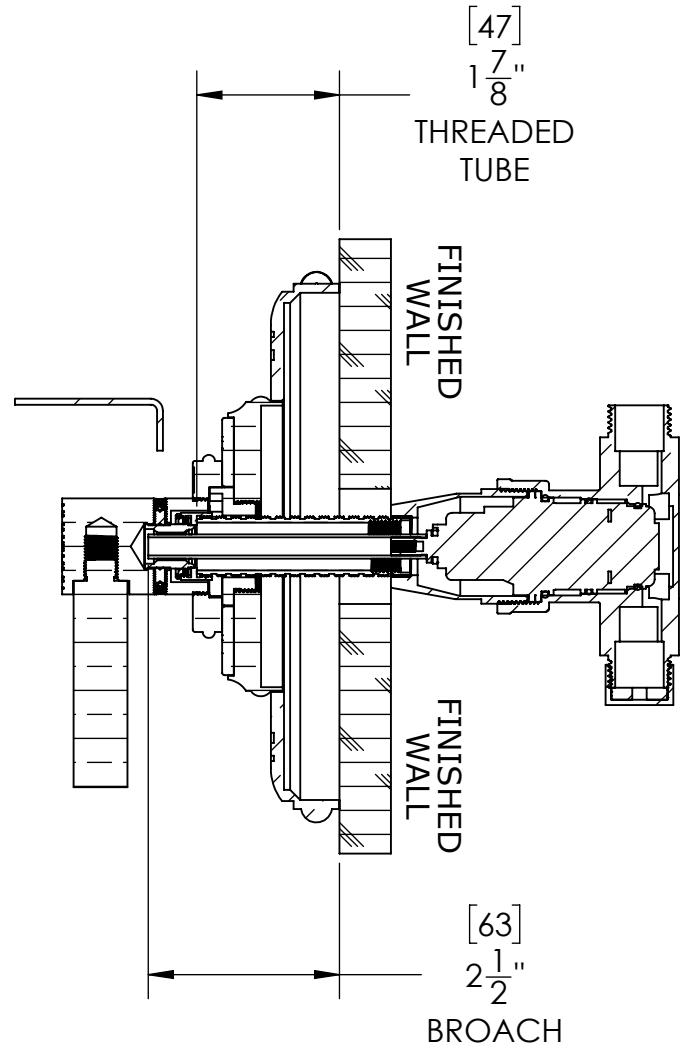
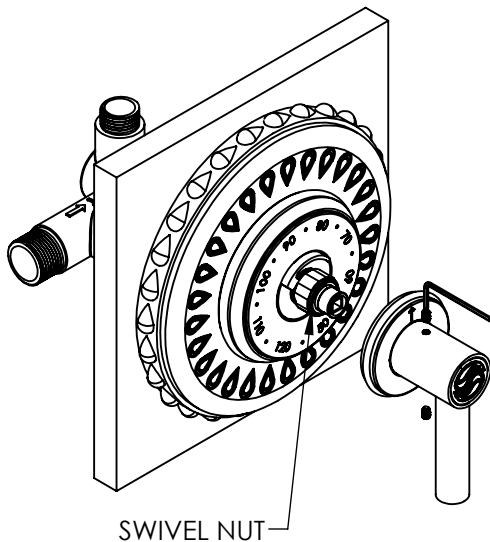

PLEASE INSPECT PRODUCT PRIOR TO INSTALLING:

Carefully review all pre-assembled parts. It will be necessary for the various parts to be re-assembled correctly.

NOTICE:

These instructions do not represent step-by-step directions. They are a product supplement only to be used by a qualified/licensed plumber. We recommend all plumbing fixtures be installed by a professional.

- Check ports for markings.
- **NEVER** use an exit as an inlet; **NEVER** use an inlet as an exit.
- All connections are NPT.
- **NO HEAT - NO TORCH.**
- **FLUSH LINES OF DEBRIS.**
- **TEST UNIT BEFORE CLOSING WALL.**
- **UPC REQUIRES ACCESS TO MECHANICAL JOINTS.**

INSTRUCTIONS:

1. Mark threaded tube 1-1/4" from the wall.
2. Mark broach 1-7/8" from the wall.
3. Cut hardware to marked length.
4. Re-install hardware to valve.
5. Install trim plate and handles in the desired orientation.
6. Tighten temperature handle with set screws.

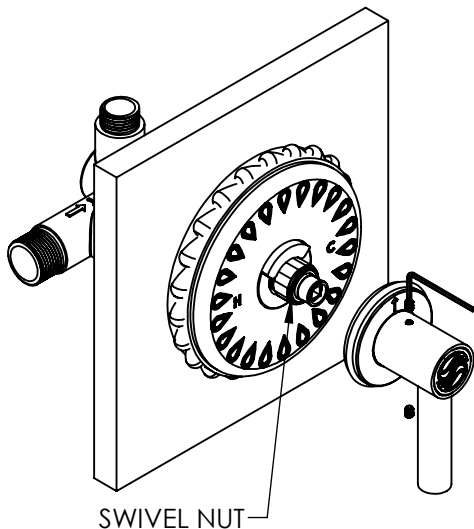
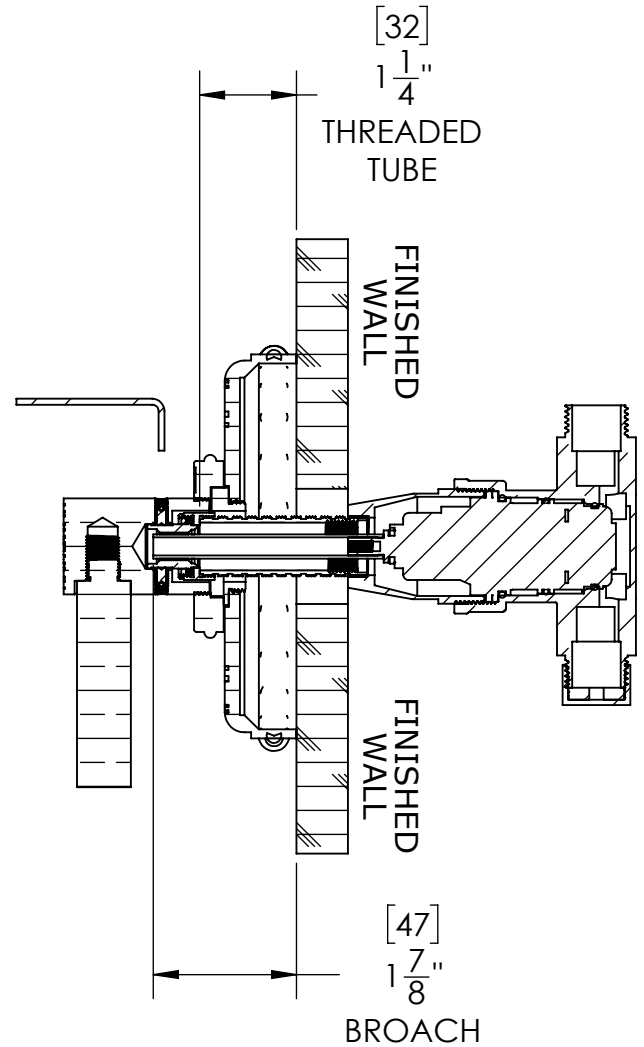

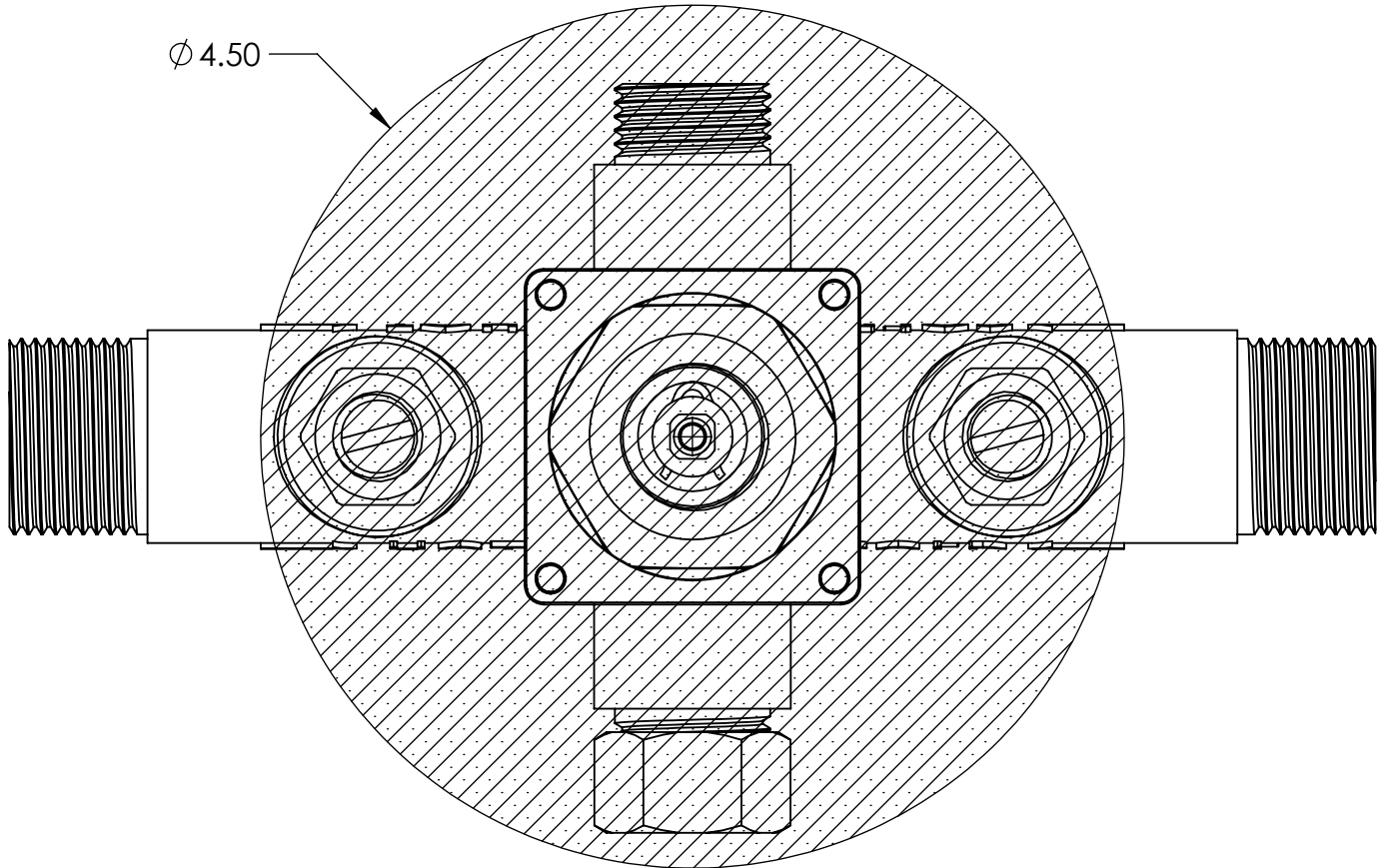

Product/Finish Warranty: Susan Dunn Inc. warrants that products are free from manufacturing defects in materials and workmanship for five (5) years from date of invoice. In addition, our Signature Finishes are warranted for workmanship only. If any material proves to be defective after inspection by our company, it will be repaired or replaced at our discretion at no charge. However, no claims for labor, shipping costs, or consequential damages will be accepted.

What we will do: We will restore any product whose finish proves to be defective back to its original finish at no charge during the appropriate warranty period stated above. Proof of purchase must be provided. After the warranty period, Susan Dunn Inc. will refinish any of its faucets at the prevailing appropriate charge.

What you must do: The faucets must be properly installed according to our instructions and specifications and are for residential use only. The faucets cannot be altered in any way. You must maintain and clean the faucets in accordance with the instructions provided with the product. You must use the faucet(s) for residential use only.

How to obtain service: Send your name, address, and telephone number along with a statement describing the nature of the problem and your paid sales slip or other proof of purchase to:

**Susan Dunn Inc. Customer Service
3280 Corporate View Vista, CA 92081**

We will then contact you and take appropriate action. Do not send us any part(s) of your faucet(s) or its various connecting hoses unless we have contacted you and have sent you an approved RGA form. All transportation charges for returned goods must be paid by the customer.

What is not covered: This warranty does not cover the crystal/glass, or porcelain products of any faucet or the drain assembly or aerator. This warranty also does not cover damage caused by accident, alterations, misuse, abuse, normal wear and tear, lime deposits, direct exposure to salty air or corrosive materials, or the color change that takes place with the passage of time, or use in any manner contrary to Susan Dunn's printed instructions. Cartridge warranties vary. Please call factory for details. In the case of in-the-wall installations, Susan Dunn. will assume no liability if there is no access. In no event will we be liable for labor of any kind, incidental or consequential damages. This warranty is extended in lieu of all other expressed or implied warranties, whether oral or written. Many installation compounds are harmful to brass and metal finishes. The use of any lead-based or acidic curing adhesive, silicone, mastic, or plumber's putty on or near our finished products will void the finish warranty. Use only sealants which are neutral curing and are not reactive with metal and brass finishes. Susan Dunn reserves the right to change, modify or alter its products as deemed necessary. This warranty supersedes any other Susan Dunn warranties, whether oral or written.

Unless otherwise contrary to state law governing the purchase, Susan Dunn's liability will not exceed the wholesale price for the Susan Dunn Inc. product considered defective. This warranty gives you specific legal rights, and you may also have other rights which vary from state to state. Some states do not allow exclusion of incidental or consequential damages, so the above limitation may not apply to you.

LIFETIME WARRANTY ON 1/4 TURN CERAMIC DISC CARTRIDGE

Should the ceramic disc cartridge in your faucet ever fail, Susan Dunn will replace the failed part free of charge to the original purchaser of the product. Your cost will be a \$17.95 handling and mailing charge. Labor not included. When ordering replacements, denote for Lavatory, Roman tub, or other. Include age of faucet. (This does not include Thermostatic, Pressure Balance, or Diverter cartridges.)

NOTICE

Susan Dunn's products are ICC-PMG listed with American Faucet & Coatings Corporation and are tested to ASME A112.18.1M and ASSE 1016, and comply with Section 9 of NSF 61 as well as NSF 372 for basin faucet, bar faucets, and kitchen faucets as required.